

# “Before you dig”



What's Beneath Your Feet?

Garages and Filling Stations  
- A Guide for Developers



# Acknowledgements



**Chair of the Steering Panel:** David Rudland

**Members of the Steering Panel:** Ben Thomas    Colin Brewer    Karen Toomer    Louise Siddorn    Rebekah Norbury

**Environmental Protection UK** is a national charity that provides expert policy analysis and advice on air quality, land quality, waste and noise and their effects on people and communities in terms of a wide range of issues including public health, planning, transport, energy and climate. Membership of Environmental Protection UK is drawn from local authorities, industry, consultancies and individuals who are practicing professionals in their field, or have an interest in the environment.

**Graphic Design:** Carol Bristow

**Illustrations:** OhLaLa Creative, London

**Copyright statement:** Copyright of these materials is held by the members of the Steering Panel. We encourage the use of the materials but request that acknowledgement of the source is explicitly stated. All design rights are held by Environmental Protection UK, unless otherwise stated.

**Suggested citation:** Rudland, Thomas. et al. (2020) Before You Dig, Garages & Petrol Stations, Guidance for Developers, EPUK.

**Cover image and all pictures and illustrations:** ©David Rudland, except Figures 7, 9 and 13-18 © Ben Thomas.

*Disclaimer: This guidance was produced as a result of the voluntary contribution of individuals who are supporters of Environmental Protection UK (EPUK), for which this organisation is grateful. Whilst this guidance represents a consensus view of the Steering Panel, it does not necessarily represent the view of individual members.*

*The information in this document is provided for general information purposes only. It is intended to provide guidance for those preparing to develop land occupied by road vehicle repair and refuelling operations and does not constitute legal advice. EPUK has endeavoured to ensure that all information in this document is accurate. However, neither EPUK nor any of the contributors to this guide shall be liable in any way for any for any liability, loss, damage or inconvenience arising as a consequence of any use of or the inability to use any information in this guidance. We are not responsible for any claims brought by third parties arising from your use of this Guidance.*

# CONTENTS

<b>SECTION 1 - INTRODUCTION</b>	<b>1</b>		
1.1 Purpose of this Guide	1		
1.2 Scope	1		
<b>SECTION 2 - FUEL STORAGE IN THE UK</b>	<b>2</b>		
2.1 History of Retail Fuel Storage	2		
2.2 Location of Garages and Filling Stations	2		
<b>SECTION 3 - ACTIVITIES</b>	<b>3</b>		
3.1 Filling Stations	3		
3.2 Fuels Stored	3		
3.3 Infrastructure of a Typical Modern Filling Station	4		
3.4 Additional Infrastructure	6		
3.5 Repair Garages	6		
3.6 Wastes	8		
<b>SECTION 4 - CONTAMINATION</b>	<b>9</b>		
4.1 How Contamination Enters the Environment	9		
4.2 Migration and Persistence of Contamination	10		
4.3 Investigation for Contamination	12		
<b>SECTION 5 - DECOMMISSIONING</b>	<b>13</b>		
5.1 Was Closure Planned or Unplanned?	13		
5.2. Objectives of Decommissioning	13		
5.3 Statutory Obligations		13	
5.4 Temporary Decommissioning		14	
5.5 Permanent Decommissioning		14	
5.6 Unrecorded Tanks		15	
<b>SECTION 6 - GROUNDWORKS</b>	<b>16</b>		
6.1 General Safety Precautions		16	
6.2 Precautions for Working in Hazardous Atmospheres		16	
6.3 General Environmental Precautions		17	
6.4 Breaking Ground		18	
6.5 Remedial Treatment of Contaminated Ground		19	
6.6 Backfilling voids		19	
<b>SECTION 7 - CASE STUDIES</b>	<b>21</b>		
Case Study 1		21	
Case Study 2		22	
<b>SECTION 8 - FURTHER INFORMATION</b>	<b>24</b>		
7.1 Archive Records		24	
7.2 Organisations		25	
7.3 References		26	
7.4 Glossary of Terms		27	
7.5 Potential Contaminants		28	



# INTRODUCTION

### 1.1 Purpose of this Guide

This guide provides a brief description of the functioning of fuel forecourts, in particular the retail facilities used for the fuelling of road vehicles. It is intended as a general guide to the hidden infrastructure and associated ground contamination that may be present and is aimed at those planning to carry out groundworks or redevelopment activities involving ground disturbance at such sites. The guide applies primarily to those sites that have fallen out of use and which are being assessed and prepared for new purposes.





### 1.2 Scope

Petrol forecourts can be divided into the following categories:

-  Filling stations - facilities where sale of fuel is the main purpose of the business. These may range from the large combined refuelling forecourt and convenience store, perhaps including car washing and valeting, through to unmanned/remote operated forecourts dispensing only fuel
-  Garages - where the primary activity is the repair of motor vehicles
-  Service stations - where the fuel is sold alongside vehicle repair operations ranging from major repairs, through vehicle and parts sales to minor servicing.

These are facilities used by the general public. In addition there are refuelling operations, such as those facilities found within commercial premises, particularly transport depots but also factories, offices, end of life vehicle centres and council or contractors' yards. These may also have similar facilities for the fuelling of road vehicles and plant and similar apparatus and infrastructure is likely to be present at these sites.

This guide does not:

-  Cover all potential configurations and types of forecourt installations
-  Provide full technical details of the facilities used for the storage of "alternative fuels" such as CNG, hydrogen and electric vehicle charging, although these may be present at modern forecourts.
-  Cover the detailed procedures for the assessment of risk.
-  Provide detailed information on the remediation of ground or groundwater contamination which is commonly associated with such facilities. This is available elsewhere (see references).

By describing the process of retail fuel storage and dispensing the guide has been prepared to alert site workers and their managers to some of the hazards and dangers associated with these sites after they fall out of use.

## 2.1 History of retail fuel storage

The history of petrol stations is inevitably linked with that of the development and increasing popularity of road vehicles from the late 19th century. The first places that sold petrol were pharmacies and hotels. The first roadside filling station was located at Aldermaston in Berkshire from 1919. This had a 500 gallon storage tank and a hand-operated pump with fuel dispensed by attendants. Britain's first self-service petrol pump was brought into use in 1961 at Southwark Bridge, London and by the end of the 1960s self-service filling stations were opening across the UK.

In the 21st century we are more used to self-service filling stations than those with attendants. Originally much of the first motor fuel was sold by retail establishments and in one way this has come full circle with most forecourts including a retail offering on site. But with more sophisticated retail complexes so has the complexity of the fuel storage engineering developed. Early fuel storage was in small volumes in above ground tanks. Later, storage moved underground and in older systems fuel tanks and pumps were located close together, often with the pump and tank as a single unit. Later fuel tanks were made of single skinned steel, filled directly from the top.

Today, the most common construction utilises doubled skinned tanks which are filled via a "remote" or "offset" filling point, some distance from the tank itself. The tanks have become much larger, typically 30,000litre capacity or greater, and with multiple compartments catering for different fuel grades. Leak detections systems, wetstock (fuel) management/accounting and spill containment have all improved markedly in recent decades

## 2.2 Location of garages and filling stations

Traditionally, filling stations have been located in high profile locations, in particular intersection of major roads in both rural and urban environments, to maximise accessibility for motorists.

From their earliest days filling stations were located in the vast majority of villages, towns and cities, as well as private facilities at farms, haulage depots and car hire businesses. Repair garages in particular were central to the sale of vehicle fuel.

Over the last 25 years the retail sector has undergone a major consolidation with the number of filling stations declining from 18,000 sites in 1990 to just 8,384 during 2019 (Figure 1). This in turn is down from a peak of around 40,000 in the mid-1960s. At the same time there has been a move to out of town retail centres with attached filling stations. Fuel sales have largely become detached from vehicle repairs premises. Forecourts have mostly become large volume throughput sites with modern forecourt and shop facilities. This has led to many forecourts becoming abandoned, redeveloped or converted to other uses, such as for car washing or vehicle sales.

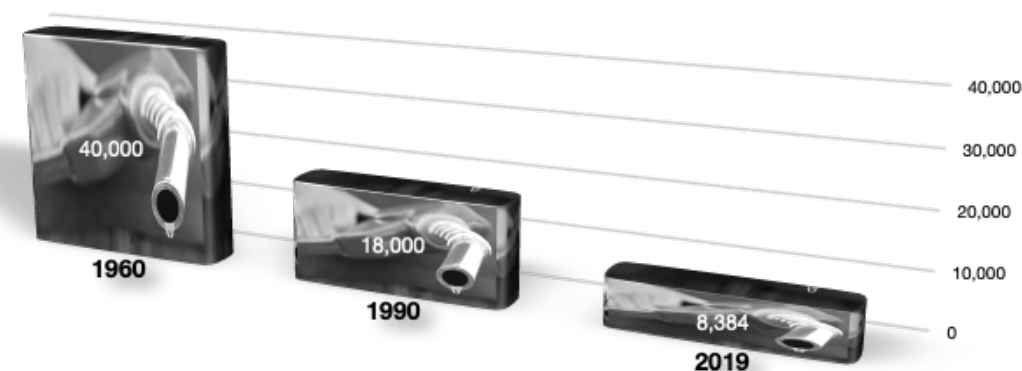
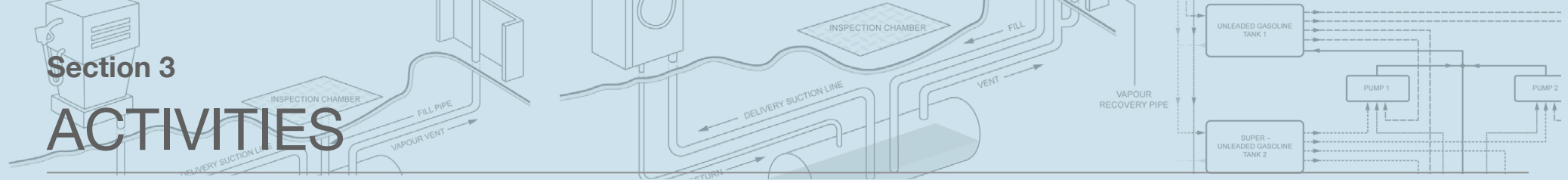

FIGURE 1 Decline of Petrol Filling Stations



### 3.1 Filling stations

Readers will be familiar with the above ground components and functioning of a typical filling station. Most are retail stations open to the public however there are many private facilities, built to serve a particular purpose. Some were located at larger private houses, farms, taxi stops and small commercial vehicle depots. Such facilities are now relatively rare for keeping and dispensing petrol because of the more onerous regulation of petrol compared with say, diesel.

By contrast there are many places where diesel is kept for private use and redevelopment of disused haulage yards often requires the removal of diesel dispensing apparatus, whether as a formal setup or “ad-hoc” containers such as plastic or steel drums and hand pumps.

### 3.2 Fuels stored

Most filling stations store as a minimum unleaded petrol, diesel and higher octane petrol (called “Super Unleaded” or described by grade such as “97 RON”). Other grades may be stored along with related fuels such as autogas (LPG) or compressed natural gas (CNG). There are a few hydrogen fuel filling stations in the UK, not specifically covered by this guide. Some filling stations are introducing electric vehicle charging points. Many filling stations, in particular motorway service stations, hold a tank of Ad-Blue, an additive used in modern diesel engines.

Older garages had separate paraffin dispensers, this fuel being used for household heating.



### 3.3 Infrastructure of a typical modern filling station

A typical filling station comprises fixed containers in which the fuel is stored, fill points in order to add fuel to the tanks, vent pipes, dispensers, road tanker delivery stands and buildings.

Filling stations are generally constructed in a similar manner, that is with most of the fuel storage underground and with the fuel lifted from its storage via pipes or “line” to petrol dispensers or “pumps” on the forecourt, where the fuel is delivered to the vehicle. **Figure 2** shows a typical forecourt pipeline layout. The pipework includes fuel feeds to the tanks and dispensers, venting pipework and for the return of vapour recovered at the point of vehicle fuelling to individual tanks depending upon grade of fuel.

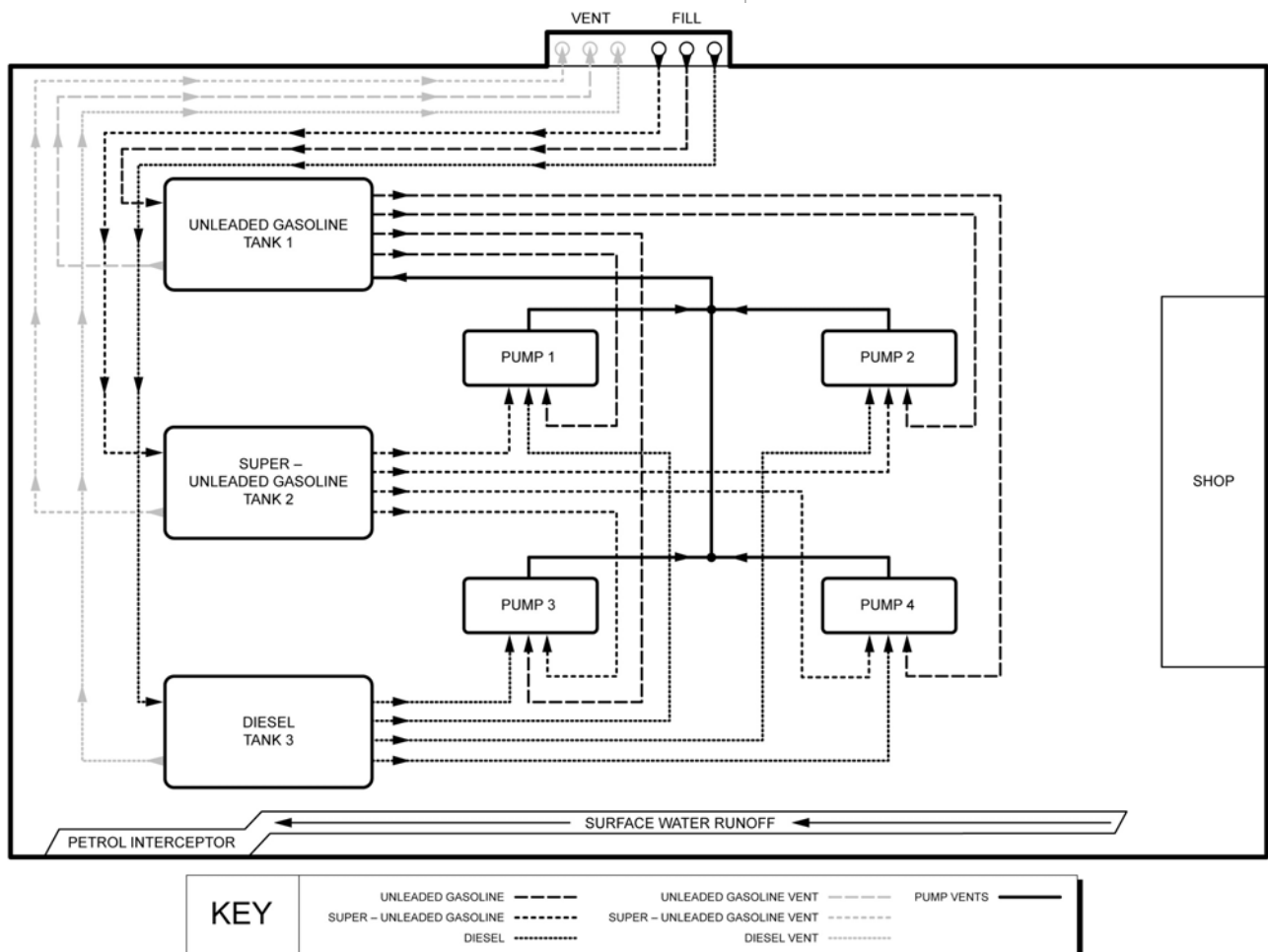
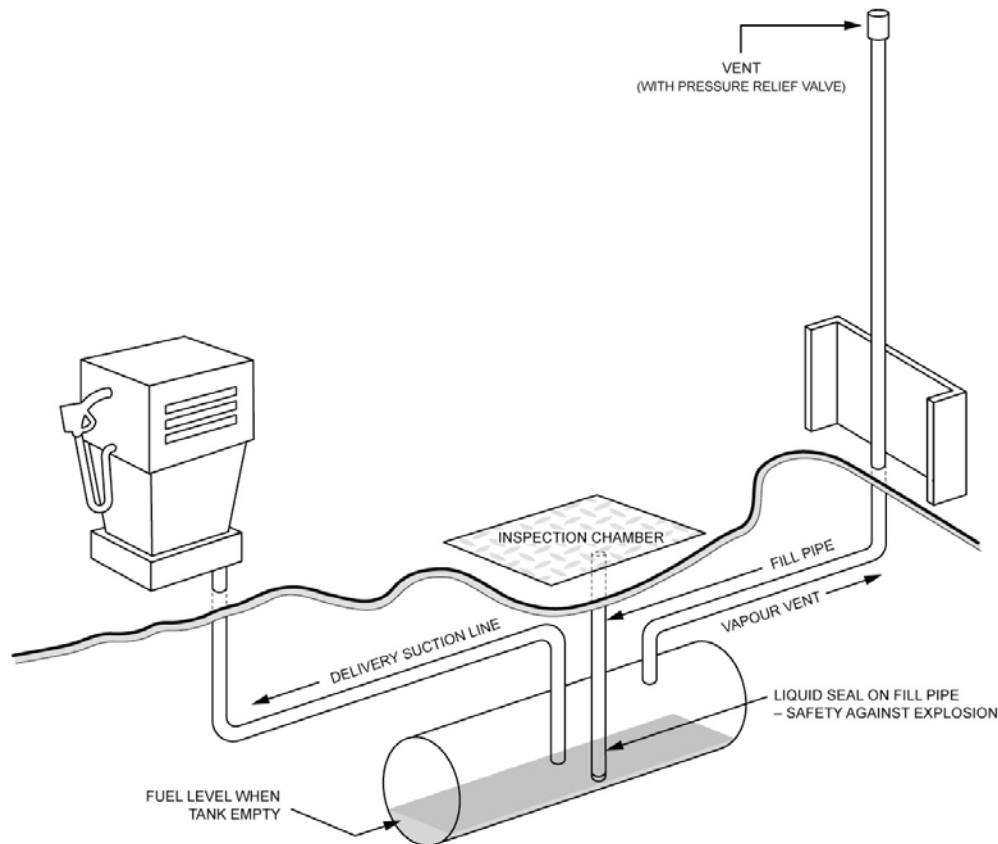

FIGURE 2 Typical Modern Forecourt Sub-surface

**Figure 3** shows a section through the forecourt illustrating the position of pipework feeding from the fill points (in this case offset fills) to and from the tanks and pumps.

Typically, until around the 1980s fuel tanks were made of single skin steel. Older underground delivery pipework tended to be steel with threaded connections.



**FIGURE 3 Typical Section through Forecourt (older)**

Modern tanks as in **Figure 4** are made of corrosion resistant materials (epoxy-coated steel is common) with double walled tanks to form an interstice between two tank walls. This allows for the detection of leaks from the inner or outer tank wall through monitoring of the interstice, employing a vacuum, pressure or a liquid sensor probe. Fuel is fed to and from the tank via pipework also using double-wall construction and made of fibreglass or plastic.

Fuel tanks, dispensers and nozzles used to fill car tanks employ vapour recovery, where the vapours that would otherwise be released to the atmosphere are collected, and delivered back to the appropriate storage tank storing that grade of fuel. Vapour is recovered during the process of filling tanks from the tanker.

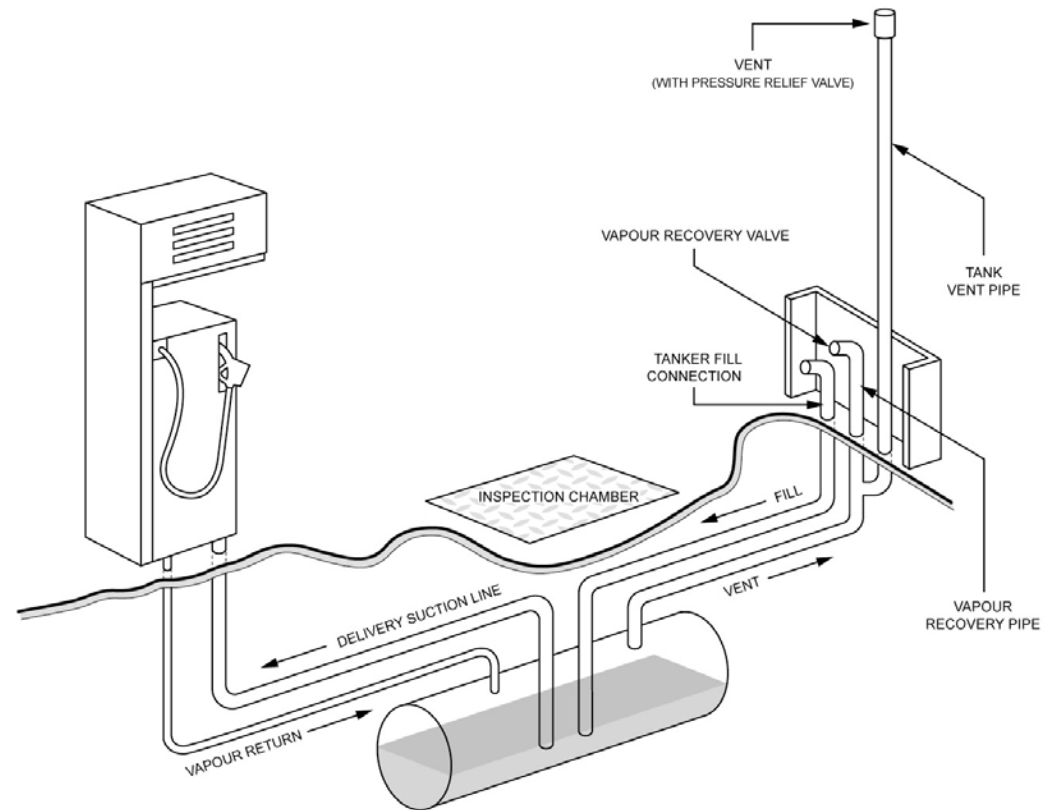

**FIGURE 4 Typical Section through Forecourt (newer)**



The area around the fuel dispensers is accompanied by a dedicated drainage system. As fuel is sometimes spilt on the ground, as little as possible should be allowed to penetrate the soil. Any liquids on the surface of the forecourt, including rainwater as well as fuels, will flow into a channel drain before it enters a fuel interceptor. The interceptor is designed to capture any hydrocarbon products and separate these from the rainwater which is allowed to proceed to a foul sewer, stormwater drain or to discharge to ground via a soakaway

Other important features of filling stations include:

- 🔧 Venting of the tank - required when filling and dispensing of the fuel. Vents are provided in order to allow air to be drawn into the tanks as liquid is dispensed and as an emergency pressure release for the tank vapour recovery system.
- 🔧 Vapour recovery - the process by which vapour displaced during the filling of a container by fuel is fed back to the ullage of the container from which the fuel was discharged.
- 🔧 Sumps and chambers - such as tank chambers holding pipework, tank gauging and leak detection equipment, under-pump chambers including pipework.

**Figure 5** shows a typical modern forecourt under construction. Note a plethora of fuel connections between the fill points and pump islands.



### 3.4 Additional infrastructure

Many modern filling stations are associated with convenience stores and car cleaning facilities. Convenience stores may sell a range of food and drink, plus household products and clothes, and include a cafe. These may be operated in the same manner as any other retail outlet, albeit that there will be staff present trained in the operation of the fuel storage and dispensing apparatus. A minority are associated with vehicle repair workshops.

### 3.5 Repair Garages

Repair garages, whether or not also dispensing fuel, may store a wide range of components and fluids used in motor vehicle repairs.

In the early days of motoring it was common for the local garage to carry out most repairs from general maintenance, fitting new parts and body repairs including application of paint. Now it is more common for different tasks to be carried out by specialists – tyre centres, body repair workshops, auto electricians and so on. Nevertheless there are many sites still catering for general vehicle repair and service, whether one-person businesses or franchised main dealerships.

Many garages once served fuel on the front of their premises to encourage potential vehicle buyers to stop and view the showrooms behind. The fuelling apparatus, although long abandoned, often remains with few if any records of whether or how it was left.

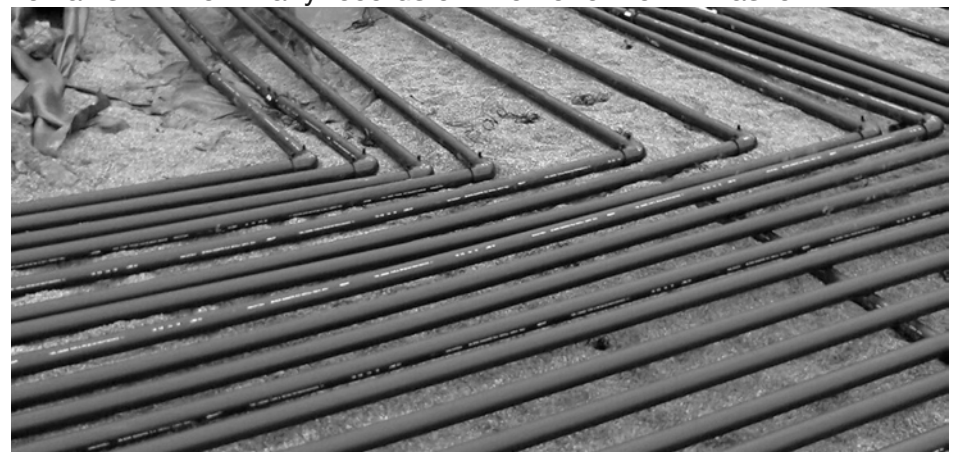

## Lessons Learned and Tips Box 1







A well-known supermarket chain decided to redevelop a former franchised car dealership showroom site for a new food store. At planning stage the development team was advised by the local authority that petrol had once been served at the forecourt in the front of the showroom, but that this had ceased during the 1980s.

The local authority advised the developer that the forecourt's tanks were likely to be located below the proposed new store and that there was no record they had been appropriately decommissioned. The developer was slow to act on this information and in the first week of the construction programme no less than 10 disused underground tanks were found by the earthworks subcontractor. This caused considerable delay to the programme as work was stopped to ensure the tanks were made safe and contaminated soil removed.

If the developer had acted promptly when the information was made available, then these essential safety works could have been included in the programme and standing time and costs therefore reduced.

**TIP - Always act swiftly to assess and properly address potential contamination issues to avoid risks in terms of delays, costs and public health.**

As well as fuel, repair garages handle a wide variety of vehicle fluids in bulk including:

-  Lubricating oils
-  Antifreeze
-  Brake fluids
-  Solvents and degreasers
-  Paints
-  Thinners
-  Lead acid batteries

Some or all of these may have been held in dedicated fixed containers at the premises. An additional consideration is the handling and storage of vehicle friction parts, which until at least the 1980s included asbestos components such as asbestos-lined brake pads.

All of the above may have left residues in the ground or in drains. Interceptors in particular may contain significant quantities of oils, fuels etc.



### 3.6 Wastes

Waste oils arising from vehicles have often been stored in movable drums or fixed tanks. Other waste fluids may be stored in moveable containers. Waste paints, oily rags and used car components (plastic, rubber and metal) are sometimes abandoned on sites.

In some cases this waste oil is stored in order to be burnt in dedicated furnaces to heat the garage premises. This is a process controlled by environmental permit and regulated by the local authority in whose area the garage is located. There are waste oil burning heaters specially made to use this type of fuel and to minimise the emissions from the process. This practice was fairly common at repair garages and permitted under the Environmental Permitting Regulations 2010. However due to changes in the regulations to discourage this use of waste oil, permitting requirements are much more onerous and it is now uncommon for waste oil to be burnt to provide local heating.

Much of the waste arising from garage activities is hazardous waste. Any business must transfer its hazardous waste accompanied by consignment notes and if producing more than 500kg of hazardous waste per annum in Wales it is required to register with Natural Resources Wales. This should encourage the keeping of detailed records, which might be available after the premises has closed to indicate how wastes had been removed from site. Hazardous waste is called special waste in Scotland and it is not currently necessary to register as a producer of special waste in Scotland or for hazardous waste in Northern Ireland.

There are other potentially environmentally damaging routes for disposal of garage wastes. Past practice may have involved disposal of waste oils and solvents down drains. Combustible materials may have been burnt at site. Some liquids may simply have been poured on the ground and allowed to soak away, either on the garage site or on adjacent areas of land.



# CONTAMINATION

## 4.1 How contamination enters the environment

### 4.1.1 Filling stations

Contamination is associated with petrol filling stations because of the leak of fuels and other substances from containment systems and the loss of fuel to the ground whilst the fuel is transferred, whether from bulk deliveries to site or during routine filling of vehicles.

Since the 1970s most filling stations have moved from attended service (a filling station where an attendant directly operates and controls the dispensing pump on behalf of the customer) to attended self-service (filling stations where customers operate the dispenser which is activated, supervised and may be shut off in an emergency by an attendant at a control point). It is arguable that this has led to greater spillage of fuel on to the forecourt – it is still common for small amounts to be routinely lost when withdrawing the dispenser nozzle and replacing it on the pump. Over a number of years these surface spills can be cumulative and amount to a significant volume. Sometimes however the amount of fuel lost during customer self-service is far greater, such as when a vehicle fuel tank ruptures. The forecourt is thus a particular area of concern when assessing the condition of a filling station.

Although most modern petrol stations have leakage detection systems so that any leaks can be quickly addressed, some filling stations have experienced significant loss of stored fuel. Sometimes this has been because of leaking tanks.

Older (pre-1990) petrol filling stations typically stored the fuel in single skin steel underground tanks - steel containment is prone to corrosion and without any secondary containment such as the second layer in modern double skinned tanks, sometimes considerable volumes were lost to surrounding ground. Older subsurface steel fuel supply pipework and threaded connections sometimes failed, with resulting loss of fuels. Many older tanks were originally installed in concrete “cradles”, sometimes completely encasing the tank. This makes it more difficult to assess the condition of the tank and thus determine whether it has lost integrity. The cradle concrete can retain leaked fuel and thus if the concrete is disturbed for any reason care must be taken not to allow the fuel to enter the wider environment.

Occasionally a major spill of fuel occurs such as during deliveries from road tankers, and ground contamination may be centred on tanker delivery stands and tank fill points. There are even incidents of retail customers, upon discovering they have added the incorrect grade of fuel to their vehicle have emptied the contents of the tank onto the forecourt.

The interceptor is a major item of infrastructure in controlling the discharge of contaminated water from the surface of the forecourt. Although most modern interceptors are well designed to cope with the volumes of liquid collected by the drainage system older interceptors may have lost integrity by damage from road traffic and this may have led to ground contamination.

Where major spills have occurred then the surface water drainage network upstream of the interceptor is commonly the source of discharges to ground through cracked or unsealed pipes and drains. Fuel may also be carried via storm drainage some distance from site perhaps to be deposited in locations at or beyond the perimeter. It is thus not uncommon for former forecourts to affect surrounding property, groundwater or watercourses.

#### 4.1.2 Repair garages







As well as any spills and leaks from dispensing operations repair garages may store vehicle fluids in bulk. This might include hydraulic fluids such as brake and clutch fluids, vehicle oils and lubricants. Although mainly in cans and drums, some garages store oil separately in bulk tanks. Until recently, it was not uncommon for garages to store used oils drained from vehicles which was then burnt in heater units to provide heat in the workshop. Changes to the Environmental Permitting Regulations in 2016 to encourage recycling of used oil meant that most garages ceased to do this in 2013 however this led to oils being stored outside of the premises awaiting collection for recycling, with risk of leaks or spills.

## 4.2 Migration and persistence of contamination

### 4.2.1 When fuel enters the ground

Fuels and oils that escape from their containment systems may enter the ground beneath the site or around its perimeter and because of their known toxicity and persistence, may have an adverse effect on future site users, the water environment and local fauna and flora.

The consequences of the contamination of soil by spilt petroleum hydrocarbons must be considered when a site is redeveloped. As well as the known risks to human health by direct human contact with “neat” fuels and oils:

-  Those hydrocarbons in contact with the soil form an impermeable coating at the surface, which prevents water circulation in soil and gas exchange between the soil and air, causing the roots of plants to suffocate, important for landscaped areas of new development.
-  The natural processes in soil that breakdown hydrocarbons generate soil gases which may enter buildings and cause explosion and/or asphyxiation risks.
-  Hydrocarbon saturated soil can inhibit the proper curing of concrete foundations in new development.
-  The more soluble components can dissolve in groundwater – for example fuel additives MTBE & TAME are highly soluble
-  Soluble components of fuels and oils may pass through water supply pipes to affect the taste of drinking water.
-  The ground may contain water that provides potable water for the locality, or supplies local streams/rivers, and other aquatic habitats. Contamination of this water may cause local or regionally important water supplies to be put at risk.

It is thus important to understand how much contaminated ground is present and the extent of the contamination.

Once fuel enters the ground its subsequent dispersion depends on the quantity lost, local geological conditions, water movement, biological degradation and soil sorption characteristics. All of these can play a significant part in where the material goes next.

**Figure 6** illustrates what may happen when fuel is released to the ground. If a small amount of fuel is lost the hydrocarbons are absorbed by the soil and it is retained in the vicinity of the spill until the saturation point of the soil is reached. However if a significant quantity is lost, beyond the soil absorption capacity, the fuel migrates through gaps (fissures and voids) between the soil particles. In this illustration, the released hydrocarbons (often termed light non-aqueous phase liquids “LNAPL” to distinguish them as a separate ‘phase’ from dissolved or adsorbed hydrocarbons) have entered the ground and easily passed through the relatively permeable near surface layers to collect above the denser clay. There the mass of hydrocarbon collects until it finds its way through fissures and “lenses” of sand into the groundwater-bearing layers beneath.

On encountering groundwater beneath the spill it may be carried by hydraulic flow away from the site of the spill. The significantly soluble components of fuels and oils once dissolved in the water can contaminate significant volumes. Portions of the fuel mass from both the residual and free phases may volatilise (become soil gas) which may allow it to migrate relatively large distances along pathways such as soil fractures, sand layers and utility conduits. Accumulations of fuel vapours in enclosed structures such as cellars can create the conditions for fires or explosions.

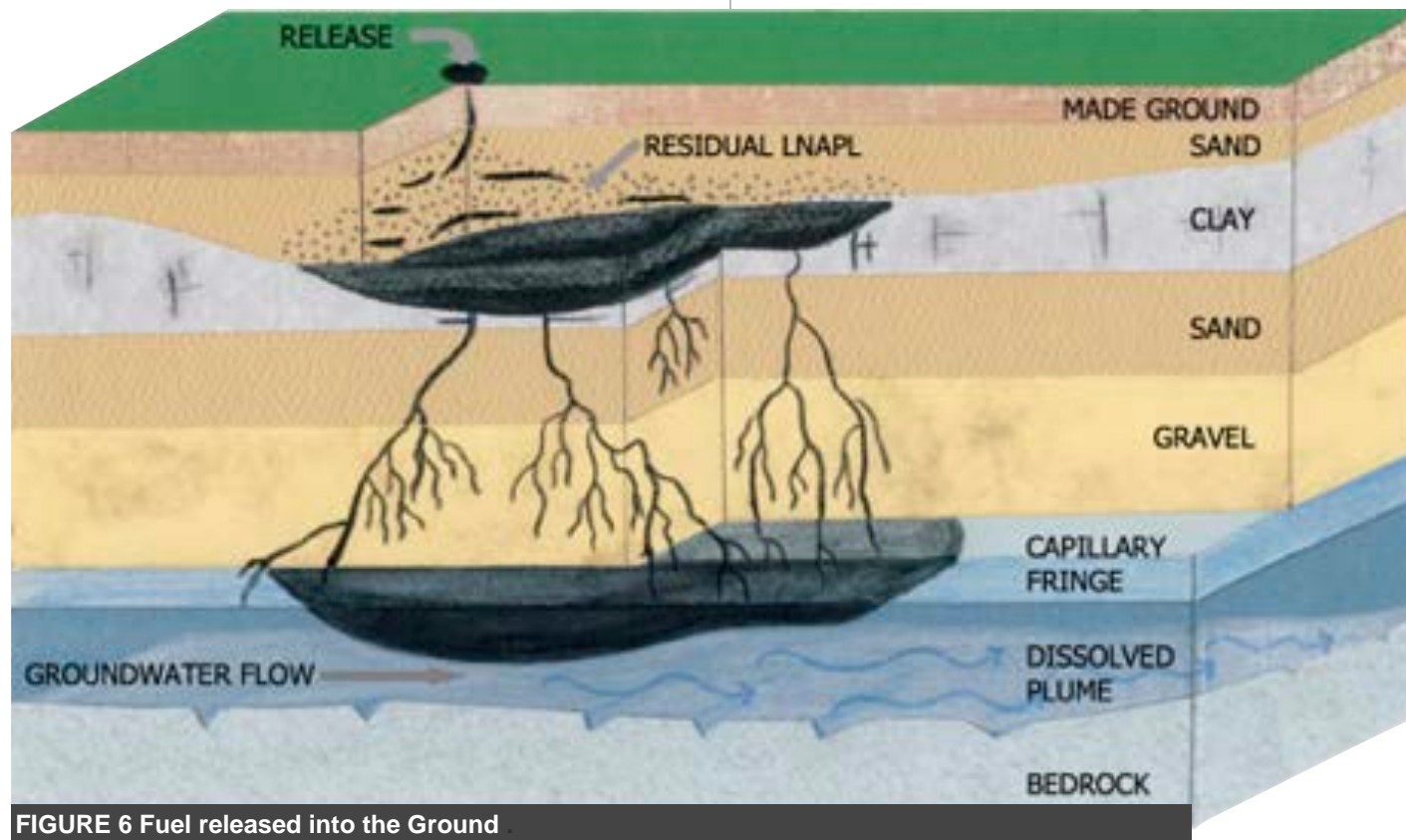

**FIGURE 6** Fuel released into the Ground

### 4.3 Investigation for Contamination

Investigation should be carried out well in advance of commencing development, to allow plenty of time to manage any pollution that is found. It is not uncommon for the subsequent cleanup of contaminated ground to require weeks or even months to complete.

Intrusive investigations (those that involve probing and disturbing underlying ground) are required where:

- 📄 transfer or sale of the site is being considered, as part of the purchaser's due diligence to ensure the site is economically developable and/or excessive liabilities are not inherited
- 📄 a garage is suspected of having caused significant pollution, such as oil seen in a nearby watercourse or fuel odours in a nearby building
- 📄 conditions attached to a planning permission require this
- 📄 the condition and whereabouts of disused storage facilities is unclear or unknown
- 📄 due diligence and liability for petroleum companies requires it.

A typical site investigation will comprise at least 2 stages:

#### Phase 1:

- ✓ Site history and land uses
- ✓ Environmental setting (geology, hydrogeology etc)
- ✓ Layout of premises and decommissioning records (if any)
- ✓ Site walkover, to identify the location of key features

#### Phase 2

- ✓ Boreholes or pits constructed to sample soil, soil vapour and/or groundwater

- ✓ Analysis of soils to identify residues of materials handled at the garage (and other land uses if appropriate)
- ✓ Post investigation monitoring of groundwater contaminant concentrations, groundwater chemistry and elevations, "free phase" hydrocarbons, soil gases and vapours.

The design and implementation of the site investigation, and interpretation of the results of these investigation phases must be carried out by a suitably qualified and experienced person. The outcome should be a fully characterised site with as much knowledge as possible of the nature and extent of the contamination.

#### Tips Box 2

Former retail filling stations should normally be identified during the Phase 1 Preliminary Risk Assessment process. Private storage and dispensing facilities are harder to identify so a site walkover visit by a specialist is always recommended before any ground disturbance is contemplated.

**TIP - Look out for the tell-tale signs such as disused dispensers, vent pipes, and lift inspection covers which might reveal tank access points. The Local Authority Contaminated Land Officer may be aware of a site's former use and should usually be consulted for information. In addition the Petroleum Officer at the Local Authority (or the Fire Service in some cases) may hold information on current or former petrol filling stations. Finally Planning records may contain information regarding the presence or absence of petrol fuelling facilities on a site, even within seemingly unrelated submissions, such as those for advertisement signage etc.**

Further detail on the design and carrying out of ground investigations is found in BS 10175:2011+A2:2017 and EA (2019)

# DECOMMISSIONING

## 5.1 Was closure planned or unplanned?

This guide assumes that work is planned on a decommissioned forecourt. When a forecourt is taken out of use, the operator and contractors have a legal obligation to ensure that equipment is taken out of use safely and left in a safe state (see Approved Code of Practice (ACOP) L138). It cannot be assumed however, that upon closure the site has been vacated safely. The forecourt operator may have left suddenly, such as in the circumstances of financial insolvency, without time or resources to undertake the appropriate decommissioning. For facilities that have been out of use for many years the uncertainties are greater because of the loss of records relating to safety work undertaken, as well as safety requirements for abandonment of equipment being less strict than currently.

During the operational lifetime an operator may, for various reasons need to abandon individual parts of the fuel storage system or dispensing equipment or even remove the whole forecourt from use either permanently or temporarily. This chapter summarises the means by which this is typically achieved.

## 5.2 Objectives of decommissioning

Site decommissioning is intended to render the fuel apparatus safe from the risks of fire and explosion. Decommissioning is normally permanent, but temporary decommissioning is allowed in limited circumstances such as when the forecourt is expected to reopen within a certain period of time.

Decommissioning is expected to take place as soon as possible after the retail fuel operation has ceased and should include measures to make it safe from fire or explosion. It is a specialist task and should only be undertaken by specialist contractors.

## 5.3 Statutory Obligations

Under Section 73 of the Public Health Act 1961 (Section 94 of the Civic Government Act 1982 (Scotland)), there exists a statutory duty for the occupier of the premises where petrol was once stored but no longer used for that purpose to “*take all such steps as may be reasonably necessary to prevent danger from the container*”. This requirement may be applied to the owners of the site even where they are not the last forecourt operator.

The Dangerous Substances and Explosive Atmospheres Regulations 2002 (DSEAR) also apply. These regulations require that an employer classifies places where an explosive atmosphere may occur, into hazardous or non-hazardous places and further classify the areas determined as hazardous into zones of relative explosion risk as defined in the regulations. The employer is expected to take measures to eliminate or reduce risks from dangerous substances during any work carried out in these zones. ACOP L138 accompanying the regulations, provides further detail on what is expected. This explains that redundant petrol storage tanks to be left on site must be made permanently safe such as by infilling. There are various solid materials that are suitable for filling underground storage tanks in situ including sand and cement slurry, foamed concrete and hydrophobic urea amino foam. Before the infill material can be added all residual fuels needed to be emptied from the tank, which is then made safe by filling with an inert material such as nitrogen foam, nitrogen gas, water or carbon dioxide.

In a redevelopment context other requirements may be set out by local authority planning conditions, such as Site Investigation and Remediation Strategies including a Verification Plan, to be agreed and in place prior to works commencing.



## 5.4 Temporary Decommissioning

For temporary decommissioning, some tanks and pipework will have been emptied of fuel, and to avoid residual vapours these must be completely filled with water. Regulators would expect the operator of the site to make regular checks on water levels.

Alternatively the tank can be made safe as a short term temporary measure before filling, by cleaning and degassing its interior, removing residual fuel and sludge, followed by forced ventilation to enable the tank to be certified as gas-free by a competent person. This latter procedure is however likely to be a temporary solution prior to permanent filling or removal from the ground.

Usually, there is a fixed duration following certification that the tank is gas free during which works to remove the tank may be carried out. In practice this means that the resources needed to remove the tank should be available on site during the temporary decommissioning works so that tank removal can be carried out within the specified timeframe – if delayed then the temporary decommissioning exercise may have to be repeated.

## 5.5 Permanent Decommissioning

Tanks and associated pipework may be made safe by permanent infilling as described above before being subsequently removed from the ground and dismantled (Figure 7).

Where tanks are removed from the ground it is usual practice for the vent pipe risers and pipework associated with the tanks also to be removed from site to prevent confusion as to whether the process of tank removal is complete.

Further information can be found in guidance produced by APEA (2018) and West Yorkshire Fire & Rescue Service (2017).

### Tips Box 3

Decommissioning tends to focus on removal of fuels and hazardous vapours, however other substances may be present that must be considered.

Modern filling stations use leak detection systems to monitor whether fuel is being lost during normal operation of the filling station. Some systems rely on detecting the presence of fluid or changes within the fluids within the space between the walls of double skin tanks. Even where evidence is available that the tank has been appropriately decommissioned to remove fuel and hydrocarbon vapour, tanks with “Class II” liquid leak detection systems comprising interstitial liquid, often glycol, may require further assessment to ensure minimal risk of groundwater pollution from loss of any remaining liquid.



FIGURE 7 Removal of underground tank

## 5.6 Unrecorded Tanks

A garage site may have been in use over a period of 80-90 years, and during that time fuel and fluids storage tanks may have been superseded several times. Ideally certification and supporting paperwork detailing decommissioning of all fuel containing infrastructure would be provided as sites transfer between parties. This may not be the case however, and furthermore many sites, especially those more than 30 years old, may contain more than one generation of underground tanks. Other tanks may also be present that fell out of use many years previously, often replaced by the most recent set of tanks. These Unrecorded Storage Tanks (UST) may still contain fuel.

Efforts should be made to identify USTs by all available means – plans, anecdotal evidence, access covers, old maps may give clues to layout and indicators, geophysical survey (even use of hand held cable/pipework detectors can assist).

It is not uncommon for USTs to be encountered during exploratory digs, site preparation, or construction excavations. In this case an explosive atmosphere should be assumed, with work halted until assessment can be carried out by a competent individual or organisation.



# GROUNDWORKS

## 6.1 General Safety Precautions

Garages and forecourts are associated with a number of hazardous substances of which petrol is the most flammable. Petrol is a mixture of volatile components. Some of these evaporate at very low temperatures, with the resulting vapour becoming flammable when mixed with certain proportions of air. Typically petrol vapour becomes explosive at very low concentrations above around 1.4% by volume in air. Low concentrations of fuel in air and thus flammable atmospheres may persist in the voids within both disused tanks and associated pipework well after the petrol has been removed. Flammable atmospheres may be present where sorbent material contaminated with petrol is stored in containers. Unless demonstrated otherwise it should be assumed that all underground fuel storage apparatus potentially contains flammable material.

Petrol is heavier than air and thus tends to sink to a low level in confined spaces. It tends to persist in poorly ventilated chambers, pits and pipework. It does not readily disperse in still air and accumulations of flammable vapour may be present long after the liquid fuel has been removed. Therefore any basements, cellars, drains, ducts, subsurface chambers or other voids must be approached with especial caution and treated as potentially hazardous unless proven otherwise.

Petrol is a substance that gives rise to health problems following exposure and therefore handling this material is subject to the Control of Substances Hazardous to Health Regulations 2002 (COSHH). This requires minimizing the exposure of persons to the liquid or vapours and where these are present work activities must be carried out in accordance with these regulations.

Normal storage of diesel does not give rise to flammable atmospheres at ambient temperatures. However diesel fuel can form a hazardous atmosphere if it comes into contact with a hot surface or is heated to a temperature above its flashpoint. Secondary releases of diesel from leaking pipework can create mists that can ignite at temperatures and volumes significantly lower than the liquid's flashpoint. Since 2015, diesel, along with other similar fuel oils, has been classified as a flammable liquid and thus covered by the requirements of DSEAR.

Work on any construction site entails careful planning for safety (Construction Design and Management Regulations) and especially so on sites where hazardous substances are stored. It is good practice to prepare and apply Risk Assessment and Method Statements (RAMS) for each task. RAMS identify the hazards associated with each task and specify the necessary precautions to control them. RAMS are normally prepared by the contractor carrying out the task to show that all of the hazards have been identified and a plan to manage them prepared.

Ideally contractors working on fuel forecourts will have appropriate training such as Contractor Safety Passport Training or similar, that gives contractor's staff awareness of the tangible and real risks of carrying out work on a petrol forecourt.

## 6.2 Precautions for Working in Hazardous Atmospheres

It is essential that prior to the start of any work on a former forecourt the potential presence of hazardous atmospheres is established and assessed. This assessment will include a desk based study of the presence of remaining infrastructure, amount of decommissioning and "making safe" carried out before the facility closed and the results of any non-invasive testing to identify sub-surface features, such as a site walkover visit (section 4.3).

### 6.3 General Environmental Precautions

Any construction scheme needs to minimize waste, its carbon footprint and reduce consumption of resources. At a local level it should minimize the impact of vibration and light, air/dust, noise and the potential for odour pollution. The construction programme needs to include an environmental management programme addressing and planning for these.

Particularly important is a strategy to allow suspect soil to be quarantined and temporarily stored pending testing and to deal with rainwater buildup which might mobilise residual fuels in the ground. It may be necessary to have a contingency storage area where contaminated materials, such as water that may be unsuitable for discharge to sewer because of its oil content, can be held pending a decision about testing or removal for treatment. **Figure 8** illustrates the construction of a temporary lagoon for holding excess water on a former large forecourt.



**FIGURE 8** Temporary contaminated groundwater lagoon

Where fuel is still expected to be present at the start of work, The Dangerous Substances and Explosive Atmospheres Regulations 2002 (DSEAR) are likely to apply. DSEAR requires employers to ensure the prevention of the formation of an explosive atmosphere, including the application of appropriate ventilation and ensuring that any release of a dangerous substance which may give rise to risk is suitably collected, safely contained, removed to a safe place, or otherwise rendered safe, as appropriate.

The DSEAR regulations contain a specific legal requirement to carry out a hazardous area study to define hazardous zones and document the conclusions. Hazardous areas are defined in DSEAR as “any place in which an explosive atmosphere may occur in quantities such as to require special precautions to protect the safety of workers”. These zones should be identified before any work commences.

Protective equipment should be selected in response to RAMS.

Flammable vapours are a constant concern. Technical staff working at excavations at forecourts often carry a device for detecting elevated levels of the volatile substances in fuels (known as VOC). Commonly ionization detectors called PIDs are used especially where contaminated ground is suspected, enabling the detection of volatiles at the parts-per-million (ppm) level. All electrical testing equipment used at site should be “intrinsically safe” so that it can be used safely in hazardous atmospheres.

It is unusual for respiratory protective equipment (RPE) to be required for open excavation work however RAMS must take the potential/presence for VOC vapours into account.

Fire-fighting equipment should be provided during site work. Dry sand or other sorbent materials can be used to tackle small spills and leaks of liquids. Fire extinguishers are recommended in case of outbreak of smaller fires, ideally the dry powder or foam type.

## 6.4 Breaking Ground

This section discusses some of the practicalities of removing tanks following infilling or degassing. Careful planning should specify suitably sized plant with competent operators and supervision.

A breaker is usually needed to remove surfacing and underground structures, such as tank bases and bund walls. Generally, unless large tanks filled with concrete are present, a 20t tracked excavator with a breaker and an experienced operative are sufficient (Figure 9).

If removal or off-site treatment of soil is part of the Remediation Strategy, excavations should allow sufficient working area for the handling of contaminated soils and groundwater, as described in Section 6.5.



In extreme circumstances (such as for large concrete filled tanks with limited access) tanks may need to be broken or cut up in situ to allow removal. The excavator would be fitted with breaker and shears for this. Following removal tanks are usually sold as scrap metal.

Ancillary materials to be retained (such as concrete for crushing and sub-base use) might need testing to determine their suitability for reuse.

Before tanks leave site it is helpful to inspect them for holes, splits and other damage due to corrosion as shown in **Figure 10**, which would indicate leakage.

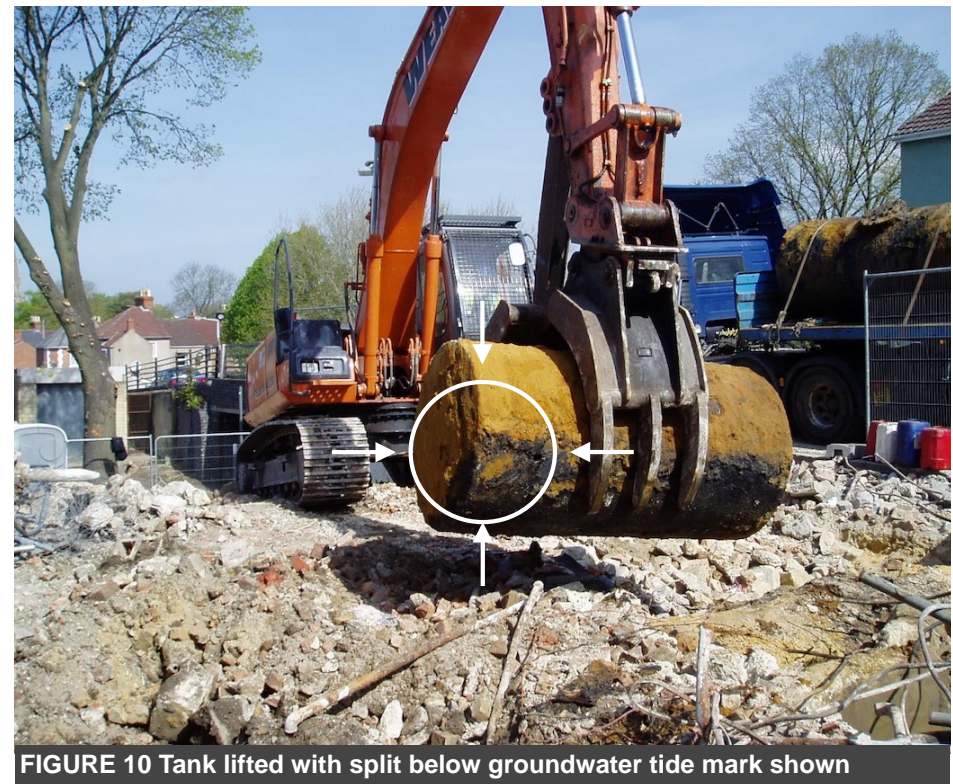





## 6.5 Remedial Treatment of Contaminated Ground

Where contaminated ground is discovered action may be required to treat this, either in-situ or by excavation to a suitable location. Sufficient time in a development programme should be allowed for the identification and management of contaminated materials.

If fuel spills or leaks have contaminated the ground, the soil will need to be cleaned up along with any floating oil and any affected surface or groundwater. Clean-up works will generally only be carried out by specialist environmental contractors. If carried out in order to satisfy planning conditions then it will usually be necessary to discuss the scope of works with the local planning authority and agree a point at which the cleanup can conclude.

It is important to remove/treat as much contaminated material as possible, because it is usually harder to remove contamination once the land has been redeveloped for new use. Following removal of the tank and any related fuel infrastructure, the contaminated material(s) encountered at each location and any other locations where unexpected contaminated materials are encountered should be excavated out as far as is practicable or until no visual or olfactory evidence (fuel odours) of contamination remains. This is unless alternative in-situ treatment approaches are preferred (see below). This will be supplemented with VOC monitoring with a PID where appropriate and where necessary backed by laboratory testing.

A treatment programme will need to know how the contamination is present, its nature and extent. Is the contamination present as:

-  Liquid phase (free-product NAPL)
-  Dissolved phase (groundwater plume)
-  Solid phase (hydrocarbon attached to soil)
-  Vapour phase
-  Combination of several of these

There are many remedial techniques in existence for cleaning up contaminated soil and new technologies are constantly appearing. Broadly these are engineering-based or process-based. However many, especially those that require contaminated ground to be extracted and treated at the surface, require specialist equipment and considerable space to manipulate and process the soil. By contrast a typical garage site is usually less than one hectare in size and thus there is rarely sufficient space for many of these techniques to be used. A more detailed discussion on the availability and choice of remedial techniques will be found within CIRIA (2004) and CIRIA (1995) however key approaches are summarised in Table 1.

It is important to consider a sustainable approach to remediation by taking into account not only the efficiency of treatment but also the energy consumption during its application.

## 6.6 Backfilling Voids

The voids created by removal of tanks and pipework may be infilled as required, either for temporary construction platforms or to facilitate construction. Infilling should only be carried out after soils tests have demonstrated successful removal of any soil and groundwater contamination within the void. However, if residual concentrations are confirmed a viable alternative in-situ treatment programme may be devised to reduce these to acceptable levels. This may be required to satisfy environmental regulators and planning conditions. Following completion of treatment programmes some verification testing of the ground may be required to demonstrate a successful conclusion.

Method	Outline	Points to Note
Excavation	Digging up contaminated soil for disposal or for offsite treatment at a "Soil Hospital".	Odours can be considerable during excavation of the most grossly-contaminated sites
Containment	Covering and containing contamination with vertical or horizontal barriers	Horizontal barriers may contain treatment "windows" that filter some dissolved phase contamination and allow groundwater to pass
In-situ extraction	Removal of liquid contamination by pumping or extraction via open voids or wells. Extraction of soil vapour via wells.  Multiphase extraction may involve combination of liquid and vapour removal	Large quantities of free fuel and oil may be collected by pumping and separation techniques. Soil vapour can be extracted from a series of wells
In-situ treatment	Addition of chemicals to groundwater to modify or destroy contaminants to make them less harmful	Treatment timescales may be significant for this type of process
Monitored natural attenuation	Monitoring of groundwater to determine whether naturally occurring contaminant attenuation processes such as adsorption, biodegradation and dispersion are occurring which can significantly enhance the rate of hydrocarbon removal from groundwater.	Very efficient and low cost clean up strategy that can be the only remedial action required, if it can be demonstrated to the regulatory authorities and stakeholders that natural attenuation is actually occurring.  Thus may require a long commitment to environmental monitoring over some years to prove successful removal by natural means.

**TABLE 1. Commonly applied options for treatment and recovery of contaminated ground**

# CASE STUDIES

## Case Study 1 The importance of pre-development site inspection

A former petrol forecourt closed and was subsequently occupied by a used car dealership. After some years and several changes of ownership all records were lost that had described how the fuel infrastructure had been abandoned. The site was approved for redevelopment.

During a site walkover a ground investigation team located several inspection chambers, as in **Figure 11**, which are a tell-tale sign that fuel infrastructure remained at site. Some of these were found to contain the original fuel fill points for the petrol station. It was clear that these had been subject to foam filling **Figure 12**.

Although encouraging this was no guarantee that the whole of the fuel infrastructure including all lines and tanks had been similarly filled and thus it was assumed that hazardous atmospheres were potentially present, especially at locations where the foam had not penetrated.



**FIGURE 11** Inspection chambers at disused forecourt



**FIGURE 12** Disused fuel filling points with evidence of foam from tank in-fill



## Case Study 2: Underground storage tank removal in microcosm

A private office car park contained a historical petrol tank that had been used to fill employees' cars. Resurfacing of the car park had covered the area and above ground infrastructure was absent. Site investigation work did not indicate any groundwater or vapour contamination was present. The final stage was to remove the tank from the car park before resurfacing.



FIGURE 13 Initial ground break

The approximate location of the tank was known, and a Cable Avoidance Tool on Radio mode was used to identify the exact location.

Expect the unexpected! Materials confirmed as asbestos cement sheeting were encountered.

These had to be hand-picked and carefully bagged for disposal by qualified personnel.



FIGURE 14 Asbestos sheeting found

Tank bedding removed by hand to identify connections and filling point and allow purging.



FIGURE 15 Bedding material removed by hand

Safe lifting point identified as flanged cover



FIGURE 16 Pipe lifting point identified

The tank was empty so relatively light plant could be used. If it had been concrete filled this excavator would have been too small.



FIGURE 17 Empty tank lifted

Remaining underground pipework chased out. Bunds left in situ (would be removed on development sites) and backfilled with arisings.



FIGURE 18 Pipework removed and tank housing area backfilled

# FURTHER INFORMATION

### 7.1 Archive Records

The local authority, or in metropolitan areas the Fire Service may, for a particular site, have records of:

- 📄 Major and minor incidents leading to local pollution
- 📄 Planning records and drawings of fuel storage
- 📄 Records of complaints made by neighbours of petrol odour and the presence of petroleum products alleged to have migrated into their land
- 📄 Any enforcement records made against the garage operators

Before commencing any work on a forecourt it is advisable to understand the history of past leaks, tank or pipework test failures, or outcomes from condition surveys that could indicate where the worst contamination might be found.

Some of the above information may be held in local history centres or archives offices.

### Tips Box 3

Although the local Petroleum Officer (PO) is likely to hold records of gasoline-containing tanks in any particular area of the UK, tanks used for the storage of diesel fuel and gas oil may not be recorded.

Some forecourts serve only diesel fuels, such as commercial vehicle rest stops or private haulage depots.

In addition there are a number of forecourts that have previously dispensed petrol, but as legislative requirements around petrol storage became more onerous, these switched to dispensing diesel only, where there was no obligation to comply with the Petroleum Consolidation Act 1928 and its replacement, the Petroleum Storage Regulations 2014. The PO was not obliged to maintain records of such facilities. Therefore some or all tanks at a site may not be documented.

## 7.2 Organisations

Table 2 lists organisations that may have information relevant to the structure and operation of garages and filling stations:

Organisation	Relevance	Links
Energy Institute	Publications on Petroleum product storage and distribution	<a href="https://publishing.energyinst.org/topics/petroleum-product-storage-and-distribution">https://publishing.energyinst.org/topics/petroleum-product-storage-and-distribution</a>
Association of Petroleum and Explosives Administration (APEA)	Training and publications, especially the “Blue Book” design guide	<a href="https://apea.org.uk/pages/publications/apea-publications">https://apea.org.uk/pages/publications/apea-publications</a>
Health and Safety Executive	Guidance on explosive atmospheres at work, storage of petrol	<a href="https://www.hse.gov.uk/fireandexplosion/petroleum.htm">https://www.hse.gov.uk/fireandexplosion/petroleum.htm</a>
Environment Agency	Guidance on protection of groundwater, management of risk at contaminated sites	<a href="https://www.gov.uk/guidance/land-contamination-how-to-manage-the-risks">https://www.gov.uk/guidance/land-contamination-how-to-manage-the-risks</a>
Petroleum Enforcement Authorities (such as London Fire Brigade)	Information on keeping petrol and historic searches	<a href="https://www.london-fire.gov.uk/about-us/services-and-facilities/services-we-offer/petroleum-enforcing-authority-pea/">https://www.london-fire.gov.uk/about-us/services-and-facilities/services-we-offer/petroleum-enforcing-authority-pea/</a>

**TABLE 2. Useful Organisations**

## 7.3 References

### British Standards

*BS 6187 Code of Practice for Demolition*

*BS 10175:2011+A2:2017 Investigation of potentially contaminated sites. Code of practice.*

### Contaminated Ground Investigation

*Environment Agency, Land contamination: risk management 2019*

### Contaminated Ground Treatment

*CIRIA, Selection of remedial treatments for contaminated land. A guide to good practice Publication C622 (CIRIA, London) 2004.*

*CIRIA. Remedial Treatment of Contaminated Land, 12 Volumes, SP101-112. (CIRIA, London) 1995.*

### Decommissioning guidance

*West Yorkshire Fire and Rescue Service, Petrol Stations - Methods of Rendering Underground Storage Tanks Safe from Risk of Fire / Explosion, Ref FS- PAN704 November 2017.*

*The Energy Institute 'Code of safe practice for contractors and retailers managing contractors working on filling stations (Energy Institute, London) 2010.*

*Health & Safety Executive, ACOP L138 "Dangerous Substances and Explosive Atmospheres Regulations 2002. Approved Code of Practice and guidance" (HSE, 2013).*

### Design of Filling Stations

*APEA and Energy Institute, Design, Construction, Modification , Maintenance and Decommissioning of Filling Stations, 4th Edition 2018.*

### Safe Working on Forecourts

*Energy Institute, Code of safe practice for contractors and retailers managing contractors working on filling stations, 2010.*

*Health & Safety Executive, Dangerous Substances and Explosive Atmospheres Regulations 2002 Approved Code of Practice and guidance L138, HSE 2013.*



## 7.4 Glossary of Terms

**Autogas:** in the UK at present, propane complying with BS 4250 sold for automotive propulsion purposes. Also commonly referred to as liquefied petroleum gas or LPG. In other countries, it may be different mixtures of propane and butane.

**Biofuel:** a blend of mineral oil derivative, typically petrol or diesel, and up to 100% biomass derived component used as a fuel for mobile or fixed engines.

**biomass** derived component: a component manufactured to a recognised standard, subsequently blended in a mineral oil derivative (e.g. petrol or diesel) and used as fuel for combustion engines. For petrol, an established component is ethanol specified to EN 15376, and for diesel, an established component is FAME specified to EN 14214.

**containment system:** the combination of storage tank, delivery, fill and vent pipework including associated valves and fittings which together provide vehicle fuel containment.

**dispenser:** commonly known as the petrol pump, located on the forecourt and is the means by which the fuel is delivered to the customer's road vehicle.

**explosive atmosphere:** a mixture of dangerous substances with air, under atmospheric conditions, in the form of gases, vapours, mists or dusts in which, after ignition has occurred, combustion spreads to the entire unburned mixture.

**FAME:** Fatty acid methyl esters (FAME) is a generic term used for biofuel derived from renewable sources.

**Interceptor:** An oil/water separator: part of the forecourt drainage system, which separates light liquid from waste water and retains the light liquid.

**LPG:** Liquefied petroleum gas – see Autogas

**MTBE:** Methyl tert-butyl ether (MTBE) is used in gasoline at low levels, replacing tetraethyllead as an antiknock additive to prevent engine knocking. Assists gasoline to burn more completely, reducing tailpipe emissions.

**nozzle:** a device for controlling the flow of fuel during a dispensing operation.

**offset fill point:** a filling point: e.g. on a filling station tank, in which connection for the hose of the delivery vehicle is at some distance from the tank.

**RON:** Research Octane Number: a measure of the knock resistance of gasoline and applied to grades of fuel.

**Remediation Strategy:** A plan for the management of hazards at site

**secondary containment:** a means to prevent loss of liquid fuel in the event of a leak or spill.

**tanker stand:** position on a forecourt where a delivery tanker is located during the unloading process.



**Danger**

## 7.5 Potential Contaminants

**Petrol** (gasoline): mixture of aliphatic and aromatic hydrocarbon compounds, ether, alcohols, MTBE, organo-lead

**Other fuels:** diesel, mixture of aliphatic and aromatic hydrocarbon compounds, additives such as FAME; paraffin

**Lube oils:** polyaromatic hydrocarbons

**Proprietary performance additives:** fuel dyes

**Metals** including naturally occurring components of crude oil e.g., vanadium, nickel, also bodywork repairs such as lead and chromium, and from vehicle paint such as lead and zinc

**Paint/coating** (other compounds): isocyanates, thinners (benzene, xylene, toluene)

**Brake fluids**

**Antifreeze** – such as ethylene glycol

**Battery acids**

**Brake and insulation components:** asbestos

**Solvents:** such as white spirit, degreasers

**Vehicle wash detergents:** alkyl sulphonates, sodium hydroxide, ethylamine diamine tetra acetic acid,



**Environmental Protection UK is an active organisation which monitors environmental issues and lobbies Government and other authoritative bodies on important issues, with the aim of improving the quality of life for all UK residents.**

**Contact us at Environmental Protection UK:** [www.environmental-protection.org.uk](http://www.environmental-protection.org.uk)

**Email:** [admin@environmental-protection.org.uk](mailto:admin@environmental-protection.org.uk)

**Charity Registered in England and Wales number 221026**

**Charity Registered in Scotland number SC040990**

**© Environmental Protection UK, June 2020**

